

Light crane system model YSK

Profiles

The YSK-light crane system is based on three optimised steel profiles suitable for load ranges up to 2000 kg. A good weight vs. carrying capacity ratio ensures maximum suspension distances leading to a reduced number of supporting structure and less suspension components.

The closed profile construction ensures increased durability of the YSK-light crane system as it protects the system against dust. All profiles are surface treated with impact resistant powder coating and can be delivered in full 1-8 meters lengths. Other colours and surface treatments are available on request.

For easy and quick installation all connections are bolt-bolt-connections.

The patented trolley is characterized by an extraordinarily low noise level and a rolling resistance of approx 1% of the moved load. YSK-light crane system brings ergonomic and quality to the working environment.

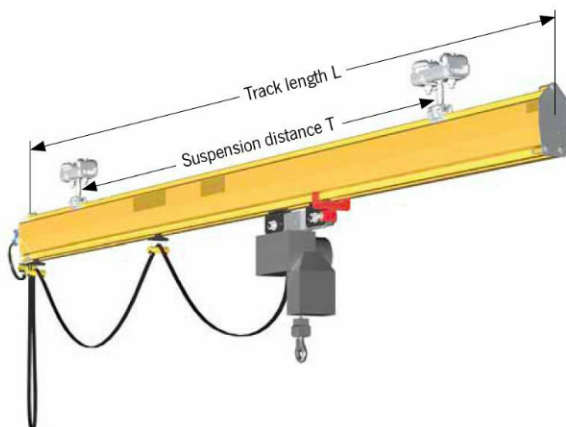

Light crane system model YSK

Hoist track

The YSK-hoist track is a versatile solution for one-way moving and lifting applications up to max. capacities of 1500 kg.

The YSK-hoist track is designed for easy assembly with standard joint connections and suspensions. It can be easily reconfigured to be adapted for changing conditions.

Hoist track – Suspension distance Tmax. in m

Profile	Capacity in kg									
	50	80	125	250	320	500	630	1000	1250	1500
YSK-125	8	7.8	6.6	4.7	4.1	–	–	–	–	–
YSK-200	8	8	8	8	8	7.2	6.2	4.4	3.6	3.1
YSK-260	8	8	8	8	8	8	8	7.1	5.5	4.9

8 m is the max. profile standard length

Light crane system model YSK

Single and double girder crane Low headroom raised construction

YSK-single or double girder cranes with raised construction help are especially suitable for applications where the lifting height is to be maximized. Raised constructions are designed for locations with limited headroom or where a standard construction would not bring the required lifting height.

A system with a raised bridge can be suspended either from existing ceiling construction or from freestanding support frames.



Raised single girder crane

Profile Track/Bridge	C	mm D	E
YSK-125	199	159	264
YSK-200	269	223	335
YSK-260	329	283	395

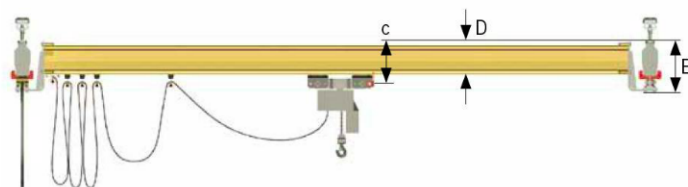

Raised double girder crane

Profile Track/Bridge	B	mm D	E
YSK-125	57	159	264
YSK-200	69	223	335
YSK-260	69	283	395

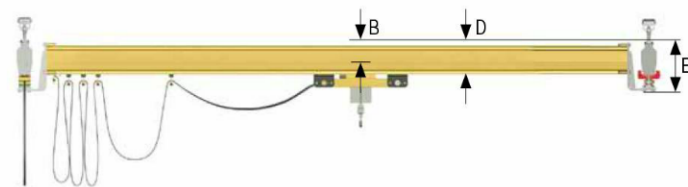

Light crane system model YSK

Single and double girder crane

YSK-single and double girder cranes are user friendly work station cranes. Their coverage is extensive and swinging of the load is minimized as the loaded push trolley centralises itself automatically to the right lifting position.

YSK-single girder crane is the most ergonomic solution due to its three dimensional construction and light own weight. With a double girder crane the load capacity is doubled and lifting height increased as the hoist is suspended from a hoist saddle located between the bridge profiles.

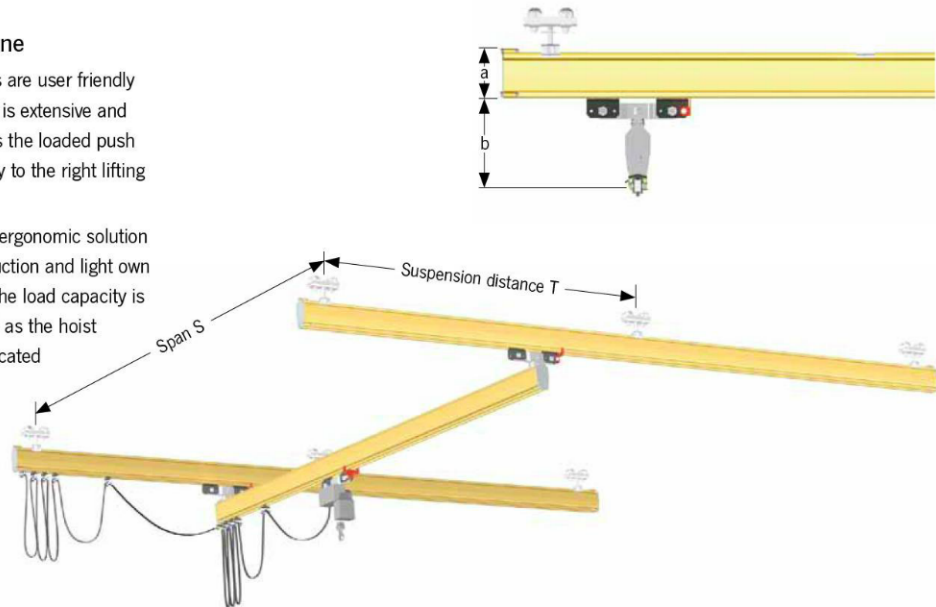

Standard single girder crane

Profile	a mm	b mm	S _{max.} / T _{max.} in meters at load capacity (kg)									
			50	80	125	250	320	500	630	1000	1250	1500
YSK-125	150	294	8/8	7.8/7.4	6.6/6.6	4.0/4.3	3.0/3.8	-	-	-	-	-
YSK-200	222	385	8/8	8/8	8/8	8/8	8/8	7.1/6.8	6.2/6	4.4/4.3	3.6/3.4	3.1/2.9
YSK-260	282	445	8/8	8/8	8/8	8/8	8/8	8/8	8/8	6.6/6.2	5.5/5.7	4.7/4.4

8 m is the max. profile standard length

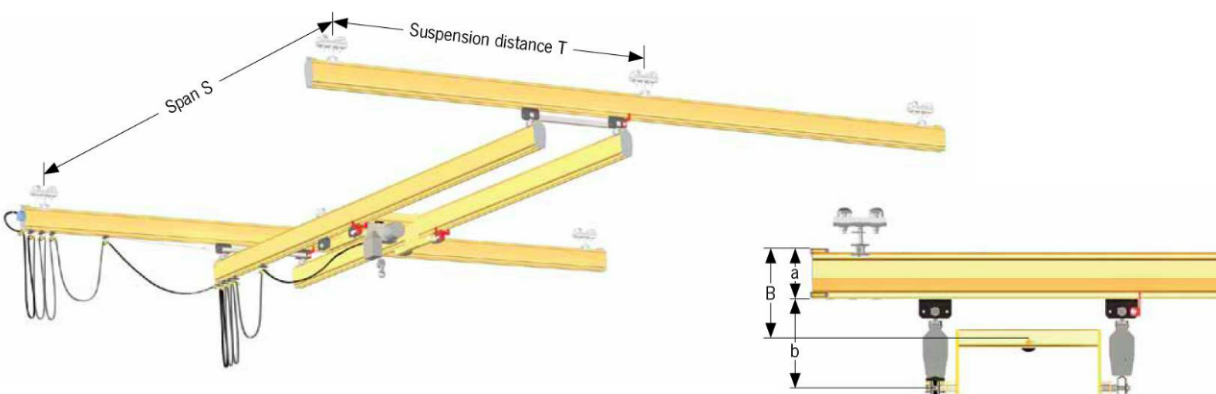

Standard double girder crane

Profil	a mm	b mm	B mm	S _{max.} / T _{max.} in meters at load capacity (kg)										
				80	125	250	320	500	630	1000	1250	1500	1600	2000
YSK-125	150	294	294	8/6.5	8/5.1	6.0/4	5.0/3.5	4.7/-	-	-	-	-	-	
YSK-200	222	385	392	8/8	8/8	8/8	8/8	8/6.4	8/5.7	7.2/4.3	6.5/3.7	5.3/3.2	5/3.1	4.0/2.7
YSK-260	282	445	375	8/8	8/8	8/8	8/8	8/8	8/8	8/6.1	8/5.2	8/4.6	7.6/4.4	6.4/3.8

8 m is the max. profile standard length

Light crane system model YSK

Articulating suspensions

YSK-light crane systems include various types of articulating standard suspensions to mount the crane to the ceiling construction.

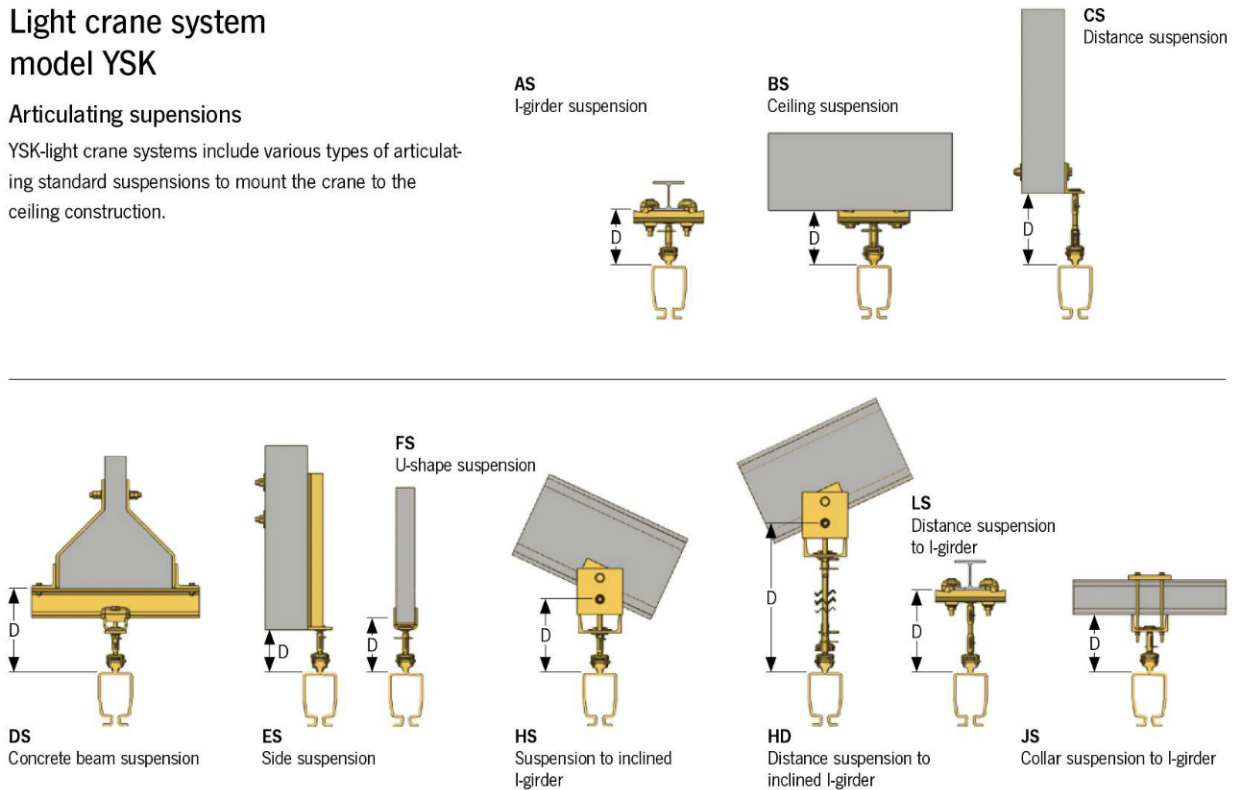

Standard suspensions

Profile	Suspension type, distance D									
	AS	BS	CS	DS	ES	FS	HS	HD	LS	JS
YSK-125	123 ± 15	123 ± 15	< 500*	218 ± 15	104 ± 15	105 ± 15	210 ± 15	< 260*	< 500*	-
YSK-200	167 ± 16	167 ± 16	< 500*	271 ± 16	136 ± 16	139 ± 16	248 ± 16	< 200*	< 500*	176 ± 16
YSK-260	167 ± 16	167 ± 16	< 500*	271 ± 16	136 ± 16	139 ± 16	248 ± 16	< 200*	< 500*	176 ± 16

*for longer distances side support must be used.

Light crane system model YSK

Freestanding support frames

YSK-freestanding support frames are designed for locations where the ceiling is not designed to support the load of the crane. This type of crane is also a professional solution for applications where the crane systems need to be repositioned to suit changes in the layout of the shopfloor.

Freestanding support frames

Load capacity, kg	50 - 2000
Total width G, m	4.5 - 8.56
Total height H, m	3 - 4 - 5
Frame width J, m	4.18 - 8.16
Single or double bridge width W, m	2 - 8

